

LV525333

circuit breaker EasyPact CVS250F, 36 kA at 415 VAC, 250 A rating thermal magnetic TM-D trip unit, 3P 3d



Main

Range of product	Easypact CVS100...250
Product or component type	Circuit breaker
Device short name	CVS250F
Device application	Distribution
Poles description	3P
Protected poles description	3d
Earth leakage protection (Vigi add on)	Without
[In] rated current	250 A at 40 °C
Breaking capacity code	F
Network type	AC
[Icu] Breaking capacity	36 kA Icu at 440 V AC 50/60 Hz conforming to IEC 60947-2 36 kA Icu at 380/415 V AC 50/60 Hz conforming to IEC 60947-2 70 kA Icu at 220/240 V AC 50/60 Hz conforming to IEC 60947-2
Utilisation category	Category A
Trip unit name	TM-D
Trip unit technology	Thermal-magnetic
Trip unit rating	250 A at 40 °C
Protection type	Overload protection (thermal) Short-circuit protection (magnetic)

Complementary

Network frequency	50/60 Hz
Control type	Toggle
Mounting mode	Fixed
Mounting support	Backplate
Upside connection	Front

Downside connection	Front
Connections - terminals	Screw connection
[Uimp] rated impulse withstand voltage	8 kV conforming to EN/IEC 60947-2
Thermal protection adjustment range	175...250 A
[Ics] rated service breaking capacity	18 kA at 440 V AC 50/60 Hz conforming to IEC 60947-2 36 kA at 380/415 V AC 50/60 Hz conforming to IEC 60947-2 70 kA at 220/240 V AC 50/60 Hz conforming to IEC 60947-2
Mechanical durability	20000 cycles
Electrical durability	10000 cycles 415 V In conforming to IEC 60947-2
Connection pitch	35 mm
Contact position indicator	Yes
Long time pick-up adjustment type Ir	Adjustable
Long time pick-up adjustment range	0.7...1 x In
Long time delay adjustment type	Fixed
Instantaneous pick-up adjustment type li	Fixed
Instantaneous pick-up adjustment range	2500 A
Height	161 mm
Width	105 mm
Depth	86 mm
Net weight	2 kg

Environment

Electrical shock protection class	Class II
Standards	EN 60947-2 IEC 60947-2
Product certifications	IEC GOST
IP degree of protection	IP40
Pollution degree	3 conforming to IEC 60664-1
Ambient air temperature for operation	-25...70 °C
Ambient air temperature for storage	-50...85 °C

Packing Units

Unit Type of Package 1	PCE
Number of Units in Package 1	1
Package 1 Weight	1.914 kg
Package 1 Height	11.4 cm
Package 1 width	13.6 cm
Package 1 Length	19.2 cm

Offer Sustainability

Sustainable offer status	Green Premium product
RECh Regulation	RECh Declaration
EU RoHS Directive	Compliant EU RoHS Declaration
Mercury free	Yes
RoHS exemption information	Yes
China RoHS Regulation	China RoHS declaration Product out of China RoHS scope. Substance declaration for your information
Environmental Disclosure	Product Environmental Profile
Circularity Profile	End of Life Information

WEEE	The product must be disposed on European Union markets following specific waste collection and never end up in rubbish bins
------	---

Contractual warranty

Warranty	18 months
----------	-----------

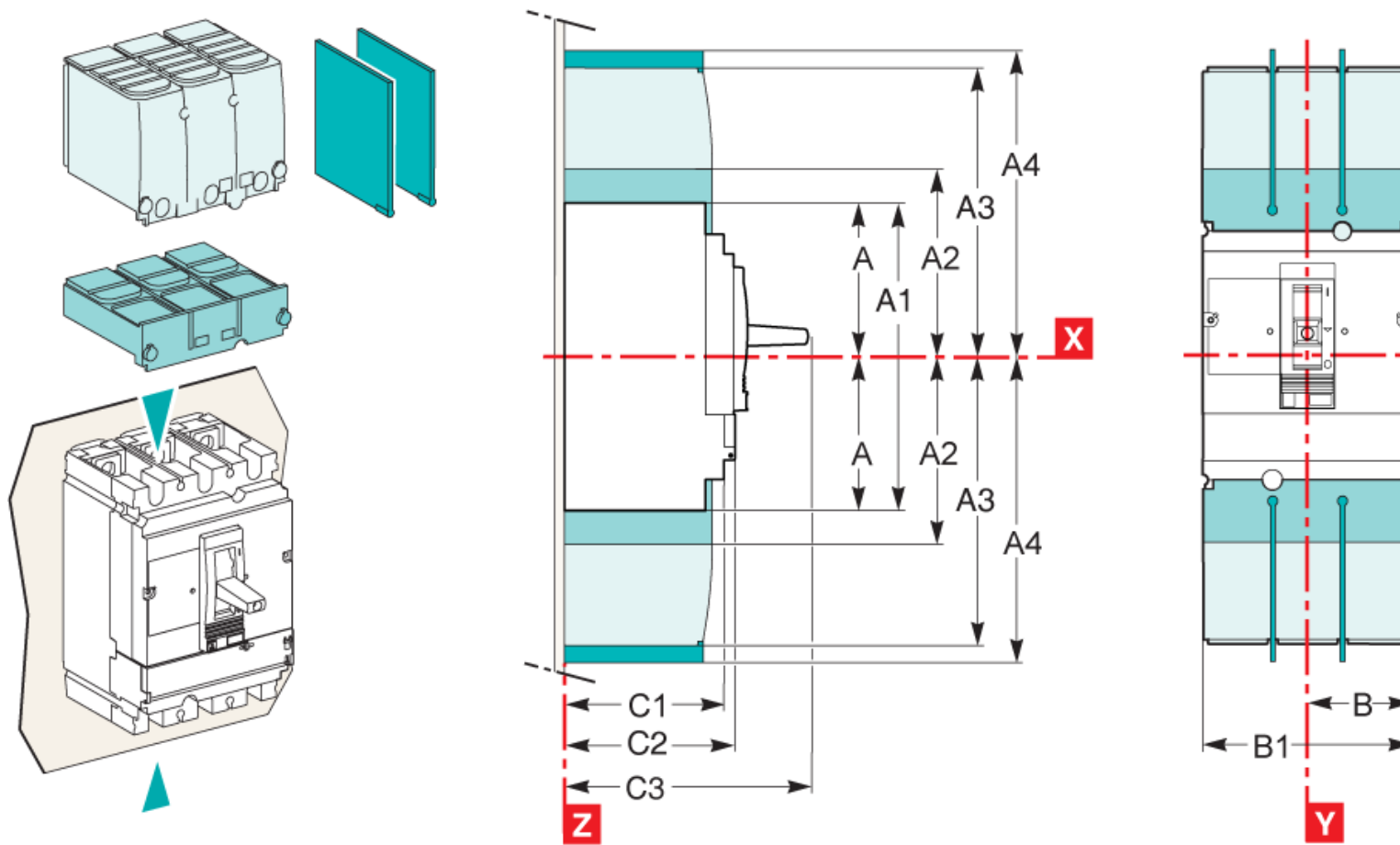

Type	A	A1	A2	A3	A4	A5	A6	A7	A8	A9	B	B1	B2	C1	C2	C3	E1
CVS100I60/250	80.5	161	94	145	178.5	155.5	236	169	220	253.5	52.5	105	140	81	86	111 ^Ø	62.5
CVS400I630	127.5	255	142.5	200	237	227.5	355	242.5	300	337	70	140	185	95.5	110	168	100
Type	E2	E3	E4	E5	E6	E7	E8	F1	F2	F3	G1	G2	G3	G4	G5	ØT	U
CVS100I60/250	125	70	140	137.5	200	145	215	35	17.5	70	96	75	13.5	23	17.5	24	y 32
CVS400I630	200	113.5	227	200	300	213.5	327	45	22.5	90	-	-	-	-	-	32	y 35

(2) C3=126mm for EasyPact CVS250B.F.

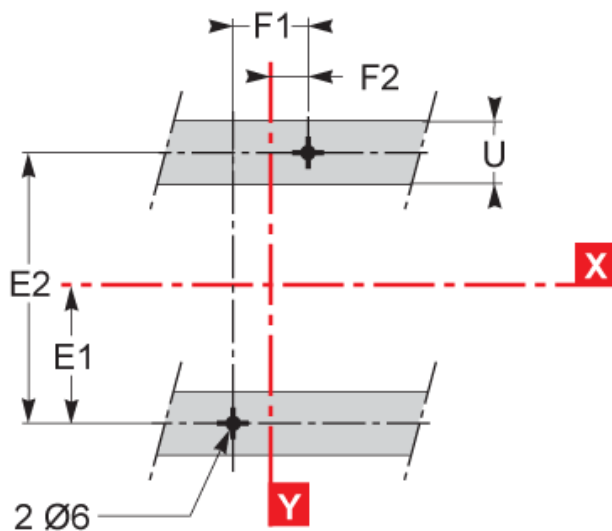
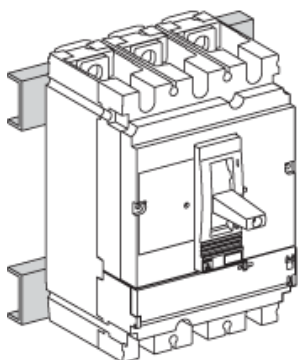
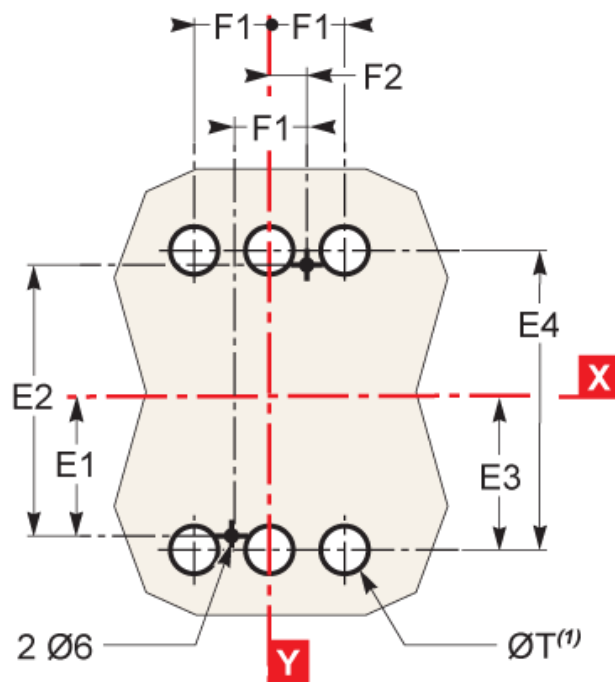
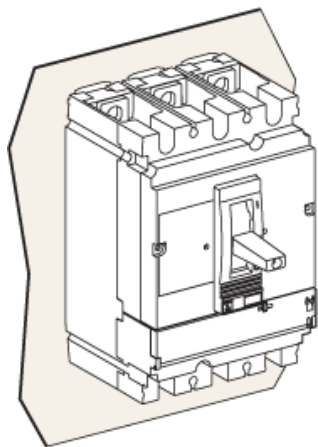

Type	A	A1	A2	A3	A4	A5	A6	A7	A8	A9	B	B1	B2	C1	C2	C3	E1
CVS100/160/250	80.5	101	84	145	178.5	155.5	236	109	220	253.5	52.5	105	140	81	86	111 ⁽²⁾	62.5
CVS400/630	127.5	255	142.5	200	237	227.5	365	242.5	300	337	70	140	185	95.5	110	168	100
Type	E2	E3	E4	E5	E6	E7	E8	F1	F2	F3	G1	G2	G3	G4	G5	ØT	U
CVS100/160/250	125	70	140	137.5	200	145	215	35	17.5	70	95	75	13.5	23	17.5	24	y 32
CVS400/630	200	113.5	227	200	300	213.5	327	45	22.5	90	-	-	-	-	32	y 35	

(2) C3=126mm for EasyPact CVS250B.F.

