

EYE NUT M16

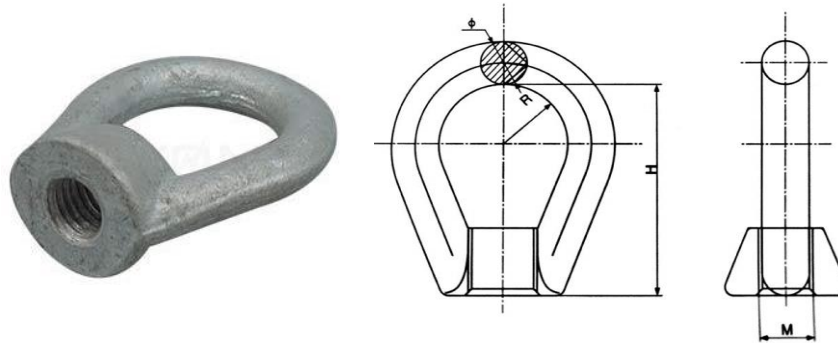

The eye nut is most commonly used for dead ending, back-guying, and attaching pole head guys on the threaded ends of cross arm bolt.

The eye nut is helpful on the overhead power lines and pole line construction.

The breaking load of the forged eye nut is more than 55kn. The surface treatment of the eye nut is hot dip galvanization. The required mark and the size 5/8 or 3/4 appear on the bottom of the eye nut.

SPECIFICATIONS

Code	Dimensions(mm)				Weight	Surface treatment
	M	H	R	φ		
Eye Nut-JY -M16	16	65	19	14	0.7kg	Hot dip galvanizing
Eye Nut-JY- M18	18	65	19	14	0.7kg	Hot dip galvanizing
Eye Nut -JY -M20	20	65	19	14	0.7kg	Hot dip galvanizing

All of the above information, including drawings, illustrations and graphic designs, reflects our present understanding and is to the best of our knowledge and belief correct reliable. Users, however, should independently evaluate the suitability of each product for the desired application. Under no circumstances does this constitute an assurance any particular quality or performance. Such an assurance is only provided in the context of our product specifications or explicit contractual arrangements. Our liability for products set forth our standard terms and conditions of sale

